

# Solder Paste Softener

Solder Paste Softener "New" in Almit product range.

## Solder Paste Softener

To mix the solder paste without opening the container. This means less oxidation less airbubbles in the solder paste and an even and repeatable mixing quality every day in the production line.

The solder paste softener is available as SPS-1 (for 1Jar), SPS-2 (for 2Jars) and SPS-5 (for 2 cartridges).



### Malcom SPS-1, SPS-2

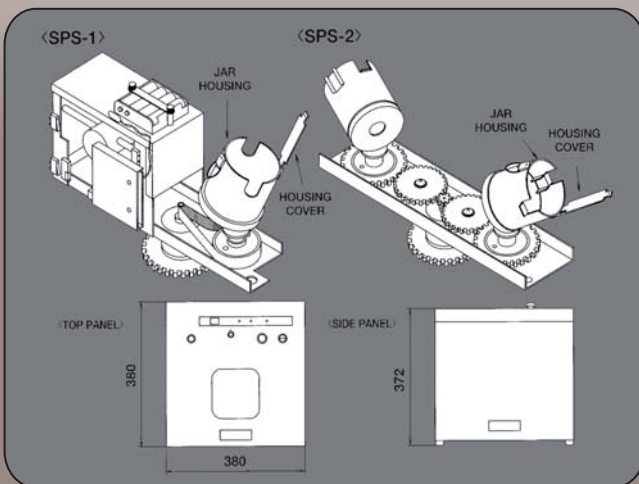

	SPECIFICATION
Mixing-Method	Pseudo-Planetary Motion
Centrifugal Force	Under 50kPa (0.5kgf/cm <sup>2</sup> )
Built-in Timer	Setting from 1 to 99 minutes
Paste Container Sizes	Solder Paste 500g: Container Size 100cc 1kg: Container Size 300cc
Rotation Balance (SPS-1 only)	Auto Balancing
Safety Interlocks	Door switch and lock/ Unbalanced motion detector
Power Supply	100VAC, 110VAC, 220VAC and 240VAC 30W 50/60Hz
Substantial Power Supply (SPS-1 only)	Alkaline Battery: Size AA Battery x 4 for Auto Balancer
Weight	Approx. 20 kg

### Malcom SPS-5

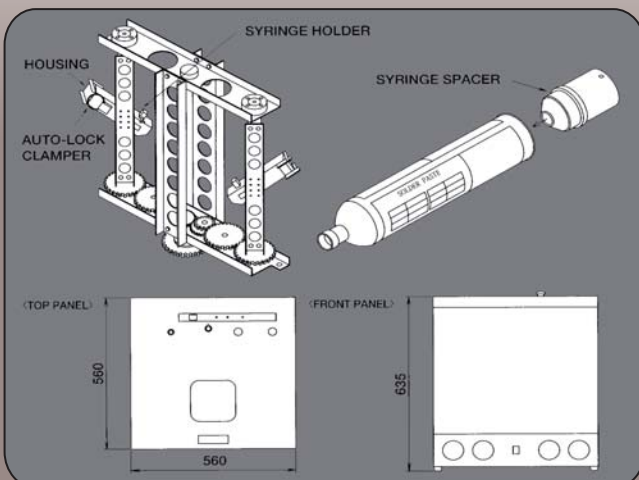

	SPECIFICATION
Mixing-Method	Pseudo-Planetary Motion
Centrifugal Force	Under 50kPa (0.5kgf/cm <sup>2</sup> )
Built-in Timer	Setting from 1 to 99 minutes
Paste Container Sizes	Up to 2 kg Cartridge
Balance	Dual Cartridges
Safety Interlocks	Door switch and lock/ Unbalanced motion detector
Power Supply	100VAC, 110VAC, 220VAC and 240VAC 30W 50/60Hz
Weight	Approx. 40 kg

\*The above specifications are subject without notice.